

KEYSTONE

CRANK SEAL

CONSTRUCTION & OPTIONS

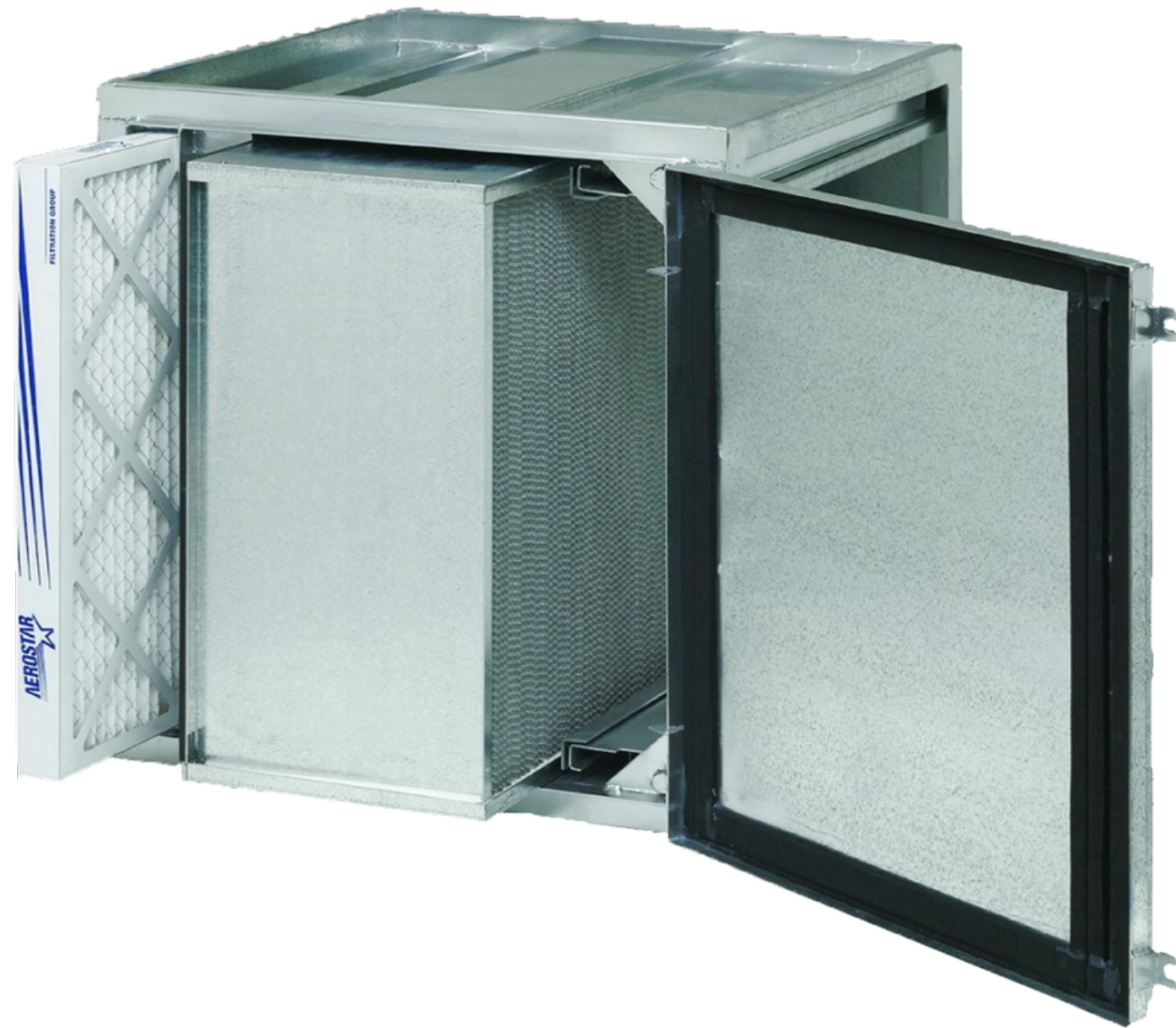

PREFILTER SIZE

- NONE REQUIRED
- 2"
- 4"

MATERIAL

- GALVANIZED STEEL
- ALUMINIZED STEEL
- T-304L STAINLESS STEEL
- T-316L STAINLESS

DOORS

- 1 DOOR **
- 2 DOORS**
 - RIGHT HAND (STANDARD)
 - LEFT HAND

CONSTRUCTION TYPE

- INTERMITTENTLY WELDED AND CAULKED
- SEAL WELDED

TRANSITIONS

- UPSTREAM
- DOWNSTREAM
- SQUARE COLLAR: H/W _____ X _____
- ROUND COLLAR: ID _____

HIGH TEMP GASKET

- YES

FILTER SEAL TYPE

- GASKET SEAL

STATIC PRESSURE PORTS

- PORTS ONLY (PLUGGED)
- WITH GAUGES
 - FACTORY MOUNTED
 - SHIP LOOSE
 - PREFILTER GAUGE
 - HEPA GAUGE
 - OVERALL GAUGE
 - MAGNEHELIC
 - PHOTOHELIC
- WEATHERPROOF GAUGE BOX

INSULATION TYPE

- 2" THICK, FOIL BACK DOUBLE WALL

WEATHER COVER

- YES

LIFTING LUGS

- 2
- 4

FLANGES

- PLAIN (STANDARD)

STANDARD CONSTRUCTION

1. UNIT SHALL BE MANUFACTURED FROM 12 AND 14 GA. MATERIAL. IF INTERMITTENTLY WELDED CONSTRUCTION OPTION IS CHOSEN, ALL SEAMS WILL BE INTERMITTENTLY WELDED AND THEN CAULKED WITH AN RTV SEALANT.
2. ALL UNITS ARE DESIGNED FOR 24"X24"X11-1/2" OR 24"X12"X11-1/2" ACTUAL SIZED HEPA FILTERS AND 24"X24"X(2" OR 4") OR 24"X12"X(2" OR 4") NOMINAL SIZE PREFILTERS.
3. ALL FILTERS TO HAVE A DOWNSTREAM SEAL.
4. LOCKING MECHANISM WILL ONLY BE OPERATED FROM ONE SIDE ON 2 DOOR MODELS.
5. UNIT COMES STANDARD WITH OUT TURNED FLANGES

STANDARD GAGE OPTIONS

UNLESS OTHER GAGES ARE SPECIFIED (REFER TO SHEET CSD-020), PREFILTER GAGES SHALL BE A MAGNEHELIC 2002 OR PHOTOHELIC A3002, THE HEPA GAGES SHALL BE A MAGNEHELIC 2004 OR PHOTOHELIC A3004, AND THE OVERALL GAGES SHALL BE A MAGNEHELIC 2005 OR PHOTOHELIC A3005. UNLESS OTHERWISE NOTED, THE GAGE TUBING SHALL BE COPPER WITH BRASS FITTINGS.



PROJECT:

275457

Revision: 0

06-13-2022

KEYSTONE

CRANK SEAL

SIZE CONFIGURATOR

H HEIGHT	WIDTH	15"	27"	39"	51"	63"	75"
	W	05W	10W	15W	20W	25W	30W

16"	05H	SIZE CODE NOTE: TO DETERMINE SIZE CODE OF DESIRED HOUSING, 05 SIZED UNITS REPRESENT A 12" NOMINAL SIZE FILTER AND 10 SIZED UNITS REPRESENT A 24" NOMINAL SIZED FILTER. IE: A 10HX15W UNIT WOULD ACCOMMODATE (1) 24"X24"X11-1/2" NOMINAL FILTER AND (1) 24"X12"X11-1/2" NOMINAL FILTER PLACED SIDE BY SIDE.
28"	10H	
44"	15H	
56"	20H	
72"	25H	
84"	30H	
100"	35H	
112"	40H	

DEPTH	
HEPA ONLY	17 3/4"
HEPA W/ 2" PREFILTER	20 3/4"
HEPA W/ 4" PREFILTER	22 3/4"

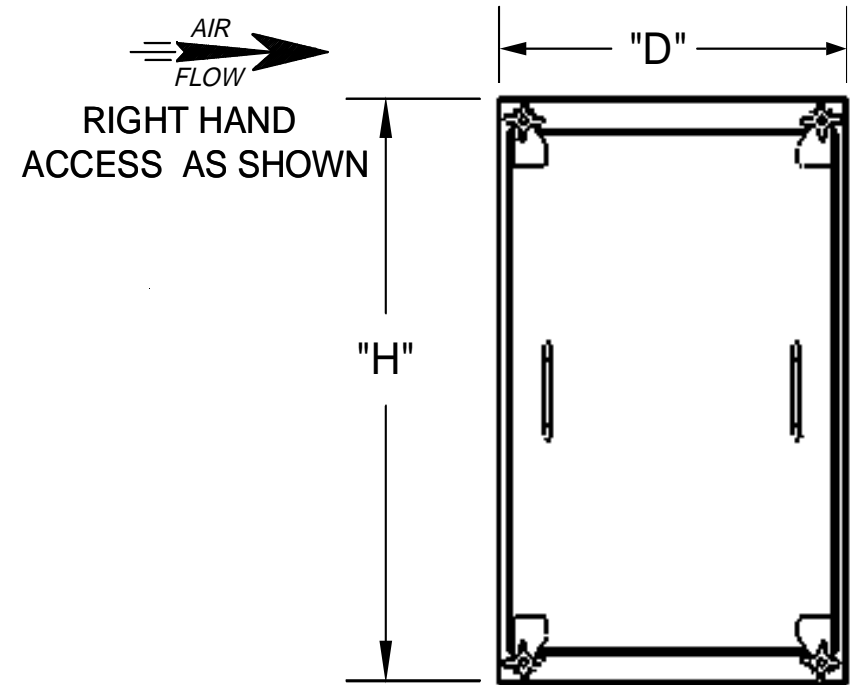

ACCESS VIEW

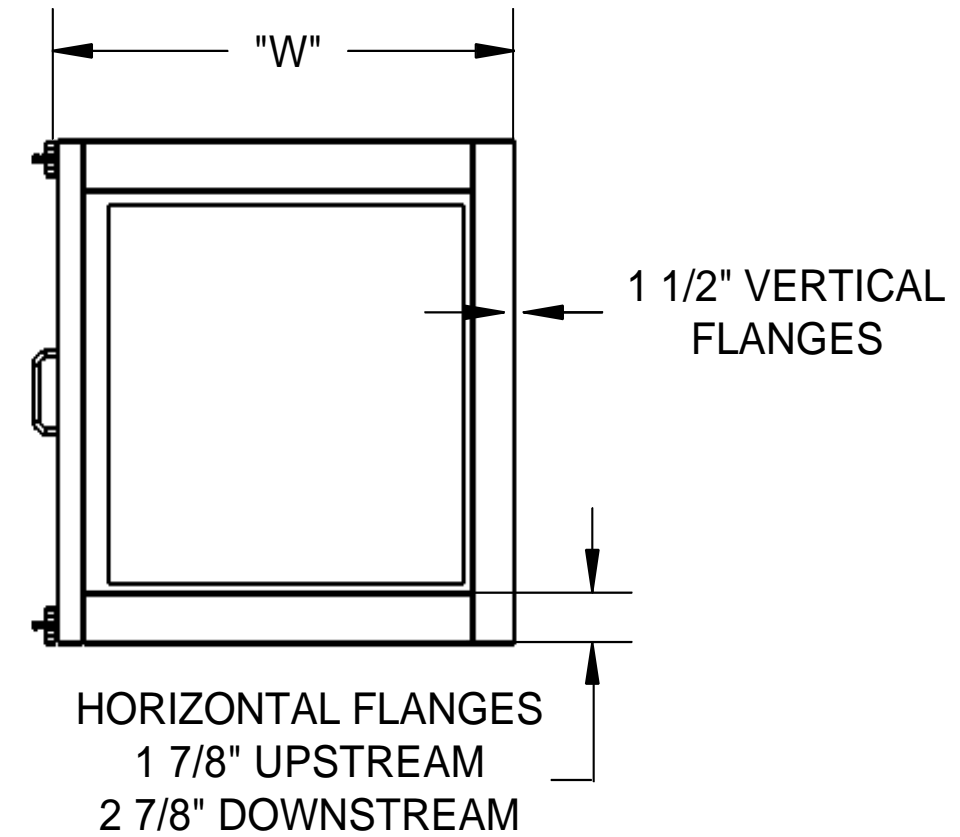

FLANGE CONNECTION

ORDER DETAILS

ITEM#	HEIGHT	WIDTH	DEPTH	QTY
1				
2				
3				
4				
5				
EX.				



PROJECT:

275457

Revision: 0

06-13-2022