

S400 Specification sheet

The S400 uses patented UVC technology, laboratory tested in bio-aerosol test chambers, to eliminate up to 99.9995% of viruses, eradicate bacteria and mold, removing up to 97% of non-viable particulates, destroying odor, and removing VOCs in a standard room in minutes!

The S400 is facility proven. Nationally recognized by hospitals like NYU Medical Center, University of Rochester, Federal VA Hospitals, NY Health+Hospitals, and Baptist Health Systems. The S400 is effective **emergency rooms, isolation rooms, patient rooms, compounding pharmacies, laboratories, food-service, waiting areas, and more.**

SPECIFICATIONS

Physical Dimensions

- 22 x 37
- Weighs 72 pounds

Electrical Ratings

- Rated at 120 volts
- Rated at 1.6 Amps
- Green Dot Grounded

Decibel Level

- 62-64 decibels Certifications
- MET US/C UL 507

Construction

- High grade steel
- Antimicrobial powder coating
- Aluminum wheel base

Air Circulation

- 400 CFM Motor Fan Speed
- Will not affect positive/negative pressure
- Air intake matches air exhaust
- 360 degree vortex air flow over a large surface area.
- Will not affect room air exchanges or room air flow.

Disinfection Process

- HEPA (0.3 um) pre-filter
- UVC 253.7nm (254 nm) 48W non-ozone light array
- Treated carbon-coir substrate final filter granulated moisture resistant

Cleaning

- Wipe down entire machine with antibiotic cleaner

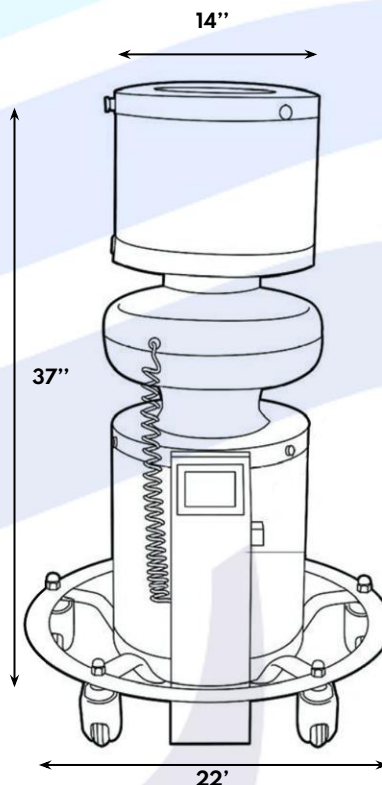

FEATURES

- Powerful 400 CFM fan performs complete air change disinfection within a few minutes in a typical room of 800 cubic feet (10'x10'x 8')
- High-capacity HEPA pre-filter reduces particulates down to 0.3 microns.
- Large-volume UVC kill chamber processing germ-laden air destroying virus, bacteria, Mold, odor, and VOCs.
- 360-degree total air circulation system is quiet, and undetectable with matching air induction and exhaust vortex.
- Zero airflow disturbance, no temperature or humidity variations, no negative or positive air pressure interference, NO by products, NO ozone.
- Lightweight 72 lbs. With aluminum balanced security base for superb stability and safety.
- 120 voltage standard outlet with the same power requirements as a typical residential ceiling fan.
- Green-Dot grounded electrical cord.
- On-Board Digital screen reporting:
 - HEPA filter/air flow integrity
 - Carbon final filtration integrity
 - UVC light intensity/integrity
 - Processed CFM air volume
- Premium hospital wheel for effortless mobility on all surfaces with touch toe locking casters.
- Consumable component "snap-in snap-out" replacements with simple and economical annual self service.
- Dimensions 22"W x 37"H 72lbs.

ScientificAir[™]
by PURO

12340 W Cedar Dr
Lakewood, CO 80228
877.452.8785
sales@purolighting.com

