

Defender — UV Air Duct

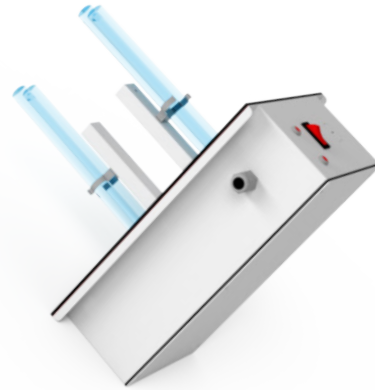

Disinfection System for HVAC

Installed inside air ducts, or the final section of the AHU (Air Handling Unit), the PURO AIR Defender disinfects the air flowing through the system and eradicates viruses, bacteria, molds and spores.

The Defender creates a UVGI barrier that inhibits the proliferation of pathogens settling inside the air conditioning unit.

In AC systems, an unsafe biofilm often covers all inner surfaces. Microorganisms proliferate due to favorable conditions such as

temperature changes, high humidity, and darkness. Defender inhibits the creation of this biofilm, increasing Indoor Air Quality (IAQ) and comfort. The Defender is important not only for IAQ and health, but for a cleaner, more economically efficient AC system, with less operational and maintenance costs. With Defender you obtain continuous disinfection of your AC system without the use of expensive and polluting chemicals.

What is UV-C?

Light in a broad sense can be divided in visible, infra-red and ultraviolet rays. Ultra-violet rays (invisible) can be classified in:

- UV-A (with tanning properties)
- UV-B (with therapeutic properties)
- UV-C (with germicidal properties)

The germicidal effects of UV-C radiation destroys DNA of bacteria, viruses, spores, fungi, molds, and mites, inactivating their growth and proliferation.

UVGI technology is a physic disinfection method with a great cost/benefit ratio. It's ecological, and, unlike chemicals, it works against every microorganism without creating any resistance.

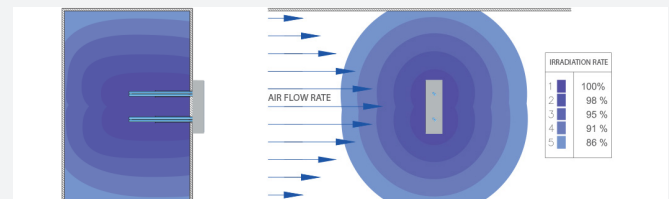

Application in a duct

TECHNICAL FEATURES

- Selective UV-C PURO AIR lamps (emission peak at 254nm) high efficiency, ozone free, pure quartz
- Body in stainless steel AISI 304
- All materials are tested for resistance to intense UV-C.
- Powered by controls enabled electronic ballasts
- Powered by 110 - 277V
- CE mark (LVD - EMC - MD - RoHS)

Defender — Simple, Small and Easy to Retrofit

The Defender family includes a range of flange modules with two “U” lamps of different sizes (from 20 to 50 cm) and power ratings (from 70W to 190W) protected by a stainless steel grid.

Compact size and on-board commands allow easy application in existing air conditioning systems. Easy to install: insert lamps within air ducts through two holes using drilling template provided, and screw flange on the external channel.

Ballasts are inserted directly inside the case and are specific to PURO AIR Duct UV-C lamps, optimizing their performances and durability.

Defender is made with high quality and extremely durable components and works perfectly in difficult operating conditions of high humidity, low temperatures, and more.

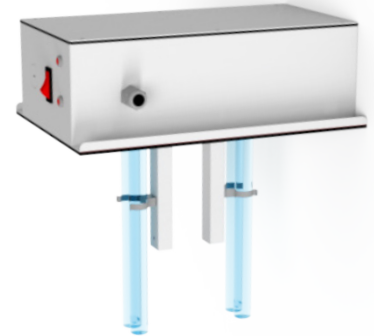

Application in AHU



One Universal Unit, Three Lamp Options

Defender UV Air Duct	Dimensions WxHxD (in)	Lamp Lifetime (up to hours*)	Consumption Watts	"A" Length Inside Duct (in)	Weight (lbs)	Protection Rating	Replacement Lamp
DF2-2L-35-ID	10.9 x 11.5 x 7.4	≤ 18,000	70	7.25	5.3	IP20	PAL-CL-35
DF2-2L-60-ID	10.9 x 19 x 7.4	≤ 18,000	120	15	5.7	IP20	PAL-CL-60
DF2-2L-95-ID	10.9 x 23.7 x 7.4	≤ 18,000	190	20	5.9	IP20	PAL-CL-95

08/2022

DEFENDER

TECHNICAL DRAWINGS

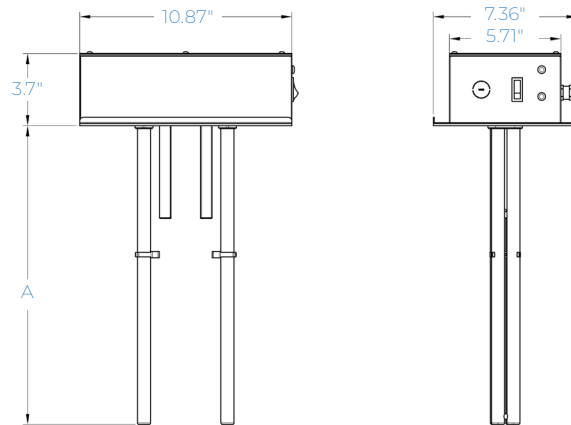

INSTALLATION

Make two holes with a hole saw on the duct you want to treat and insert the device within the holes. If you need to install more than one device, try to distribute them along the channel to create uniform irradiation and avoid shadows. This way, you can purify the airflow entirely. Our technical department designs custom layouts for clients' specific needs. Installation procedures:

- 1) Place the device/s downstream from the Air Conditioning system.
- 2) Make the two holes on the duct's wall using the drilling template provided.
- 3) Fix the device on the duct with 6 tapping screws. The six holes can be accessed on either edge of the fixture.

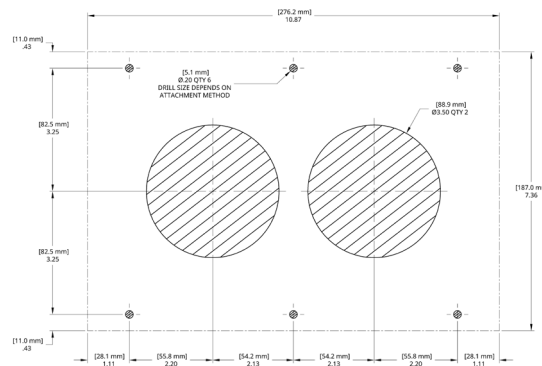

HOW TO ORDER

Please specify components below using the letter code in bold to select the desired options.

Model	Lamp Configuration	Lamp Type	Mounting
DF2 = Defender Air Duct	2L = with 2 UV-C lamps	35 = 35W mercury vapor UV-C lamp 60 = 60W mercury vapor UV-C lamp 95 = 95W mercury vapor UV-C lamp	ID = In-duct mounting
Example order: DF2-2L-35-ID			