

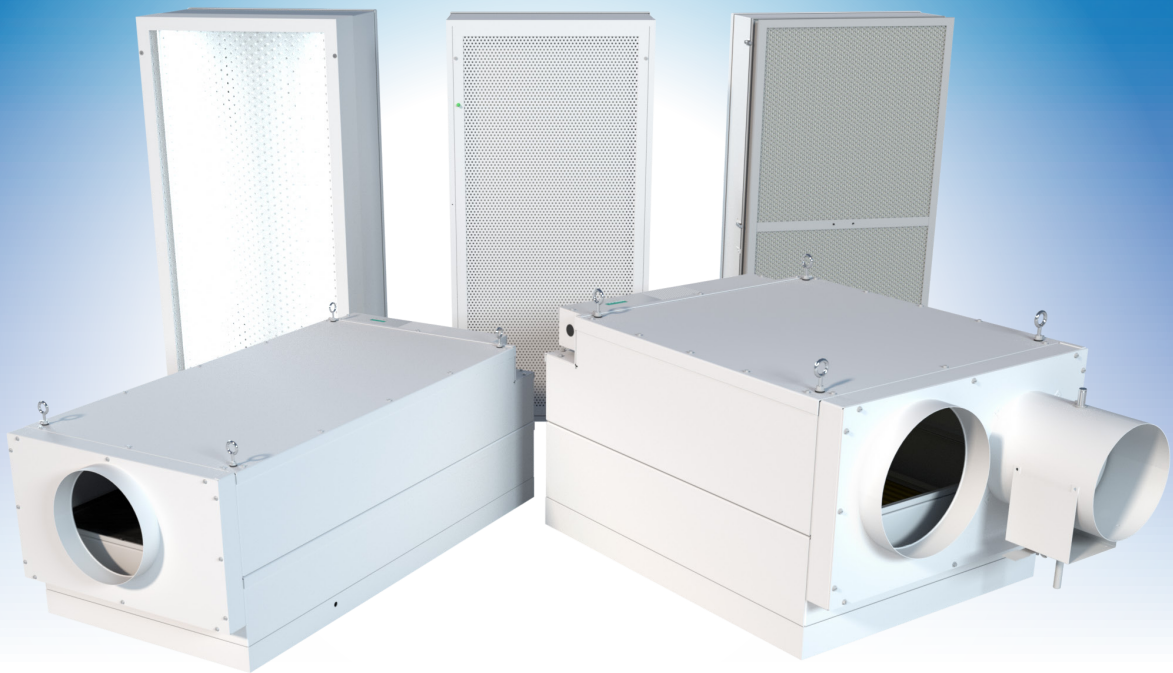

Krown

Fan Filter Units



CATALOG

v001 – Issue Date: 06/16/22

© 2022 Keystone Clean Air Solutions. All rights reserved.

Krown Fan Filter Units are the most energy efficient line of fan filter units on the market today. Designed specifically for use in cleanrooms, pharmacies, pharmaceutical manufacturing facilities and laboratories, the Krown Fan Filter Unit delivers high volumes of HEPA filtered airflow (for 99.99% removal of contaminants) at low sound levels while reducing energy consumption by 15 to 50% versus comparable products.

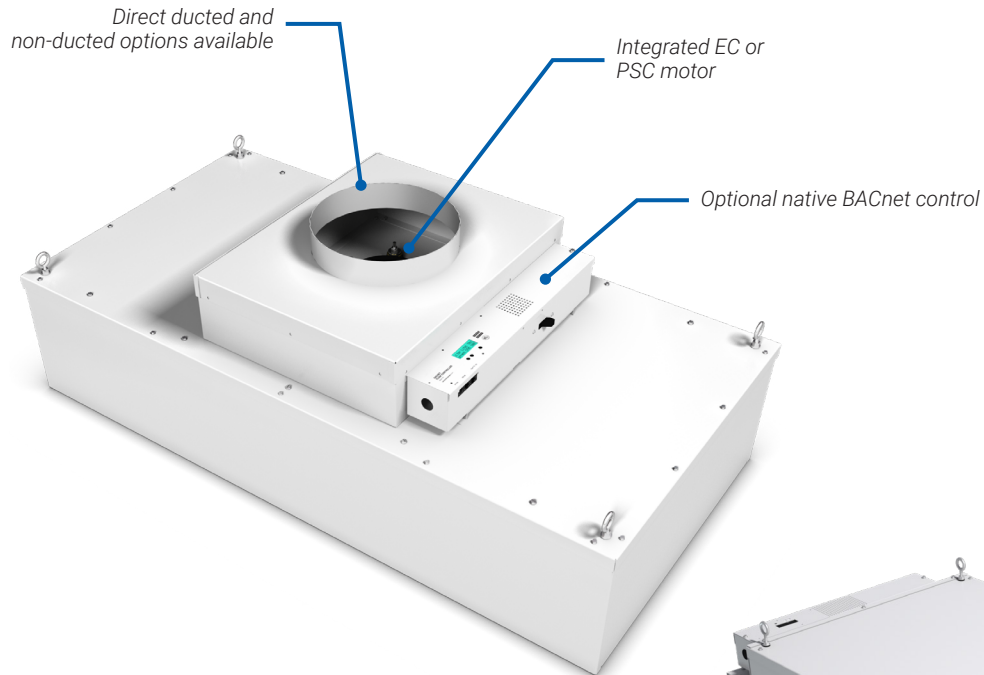

Room-side removable (RSR) filter, supply flow

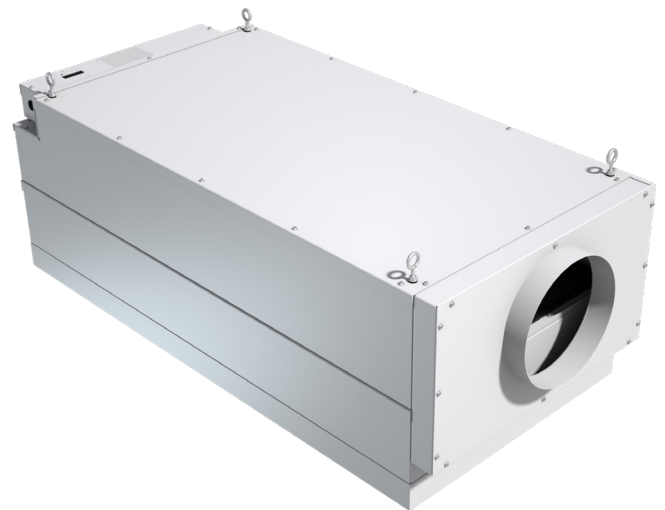

Room-side removable (RSR) filter, reverse flow

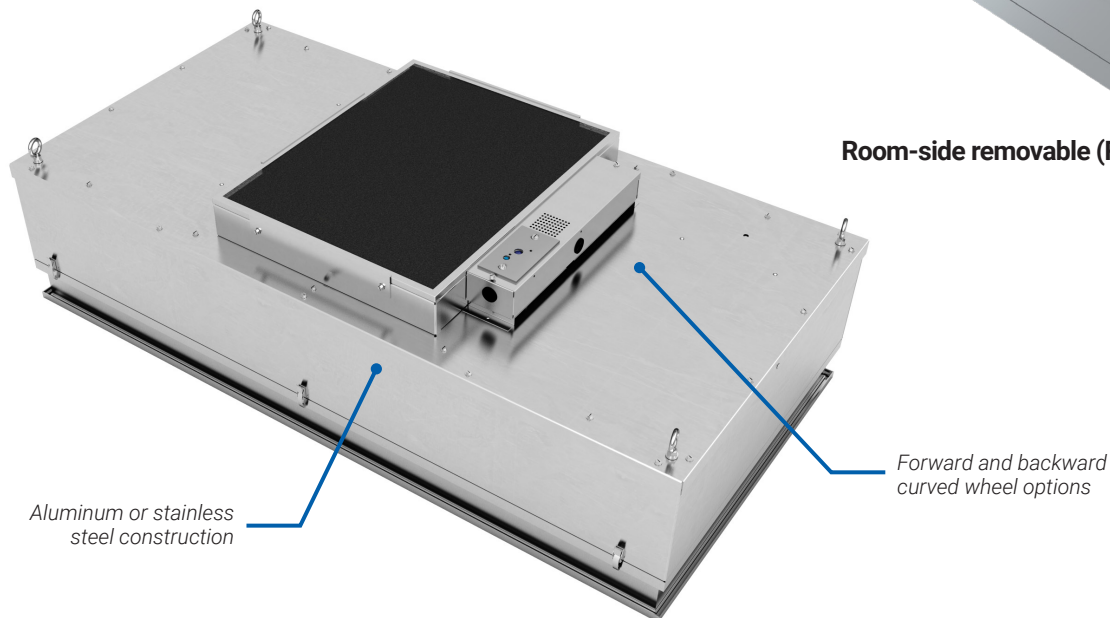

Bench top replaceable filter (BTR), supply flow

High Energy Efficiency

- Industry leading energy efficiency means lower operating costs, potentially saving thousands of dollars in electricity each year.
- Energy consumption as low as 60 Watts at 90 fpm for a 24 in. x 48 in. module.

High Airflow Capacity

- Fewer units required to meet airflow demand means lower cost.
- Active filter area is maximized with the Bench Top Replaceable (BTR) filter, with 24 in. x 48 in. units able to achieve up to 960 CFM.

Versatile Motor Programs

- Factory programmed EC motors means no-hassle startup and commissioning.
- **Constant Torque Program** – The motor operates at a constant torque, and is unaffected by change in upstream static pressure. This option should be used with an upstream, pressure-independent terminal unit.
- **Constant Flow Program** – The motor adjusts to maintain airflow rate as the filter loads over time. This option is ideal for non-ducted applications.

Seismic Certification Preapproval

- Optional HCAI special seismic certification preapproval as per OSP-0302-10 on supply flow fan filter units.

Exhaust and Reverse Flow Applications

- Optional reverse flow construction draws contaminated room air through the filter and exhausts the air to the outside or returns it to the space.
- An optional dual-outlet on reverse flow units can be used to direct filtered airflow in two directions. The dual-outlet reverse flow option is ideal for applications that require a negative room pressure and recirculated HEPA filtered airflow.



**Dual-Outlet Reverse Flow
Fan Filter Unit**

TYPICAL APPLICATIONS

Krown Fan Filter Units are used in critical applications such as healthcare, pharmaceutical compounding or microelectronics manufacturing. The high efficiency motor is designed to overcome the static pressure of the integrated filter, making Krown Fan Filter Units ideal for retrofit applications where the air handler is not able to provide the required static pressure and new builds with high air change requirements to downsize rooftop equipment.

CONSTRUCTION

- Application
 - Supply
 - Reverse Flow
 - Dual-outlet Reverse Flow (Krown-D)
- Size
 - 24 in. x 24 in.
 - 24 in. x 36 in.
 - 24 in. x 48 in.
- Material
 - Aluminum
 - Stainless steel
- Filter
 - Room-side removable (RSR)
 - Bench top replaceable (BTR)
- Options
 - Aerosol injection port (INJ)
 - Face-mounted LED indicator
 - Integrated LED lighting (Krown-L)
 - Room-side accessible controls (R+TC)

Bench Top Replaceable (BTR) Filter

- Maximizes active filter face area to allow for the highest airflow capacity.
- Less pressure drop and energy consumption compared to RSR filter.
- Filter replacement requires removal of the unit from the ceiling.

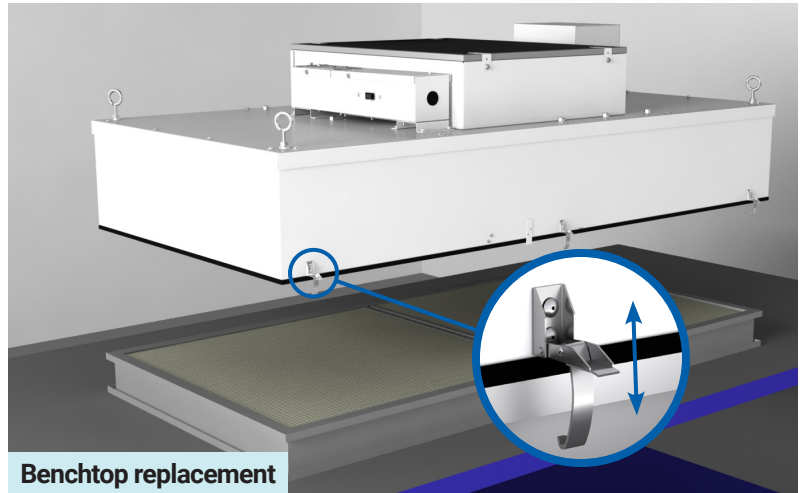

Benchtop replacement

Room-side Removable (RSR) Filter

- Quickly and easily remove the filter from the Room-side with the RSR option.
- Integrated knife edge and gel track filters allow for tool free installation and replacement.
- The RSR filter option also features a room-side removable motor/blower assembly.

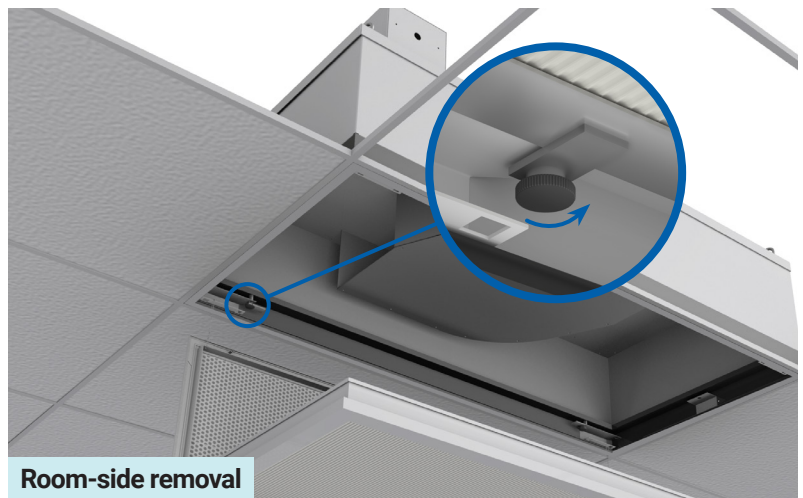

Room-side removal

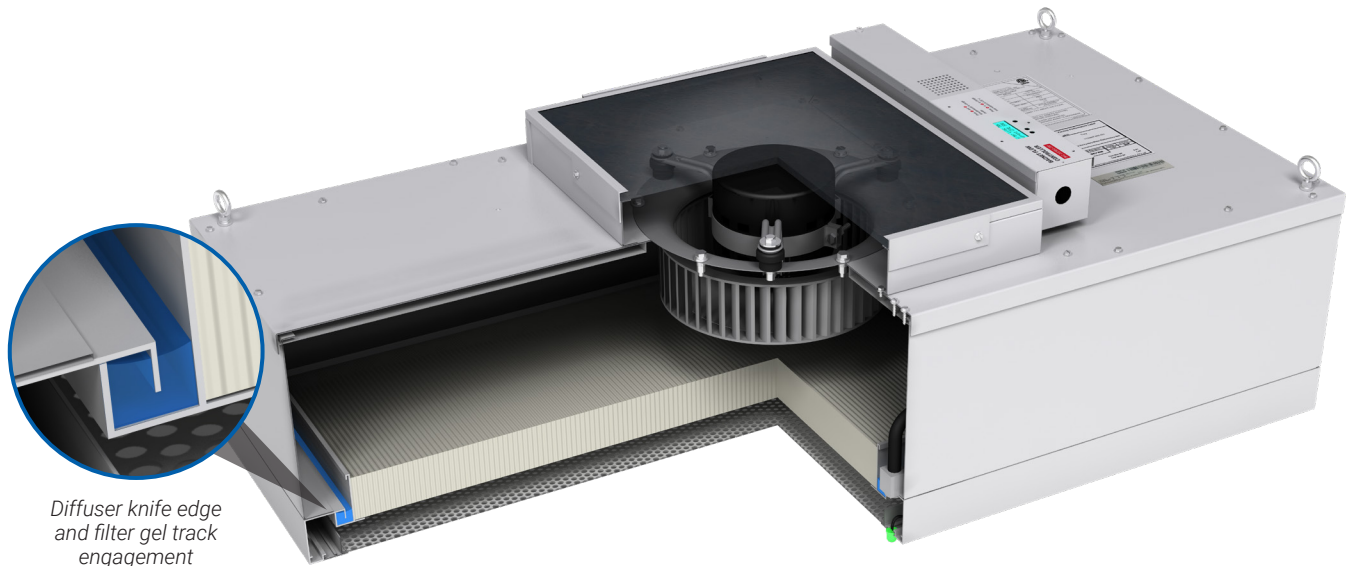

Diffuser knife edge
and filter gel track
engagement



Quick and Easy Commissioning via Aerosol Challenge

- Ensure proper HEPA filter and unit operation with the room-side Aerosol Injection Port (INJ).
- INJ permits easy injection of aerosol challenge through the barbed test port for 1/2 in. inner diameter tubing. By dispersing aerosol above the HEPA filter, the filter can then be scanned for leaks during commissioning or after filter replacement.
- A static pressure port is provided to measure pressure drop across the filter and to sample upstream aerosol concentrations during commissioning.

Krown Integrated LED Lighting (Krown-L)

Optional integrated lighting transforms a standard Krown Fan Filter Unit with room-side replaceable filter into a combination high performance LED light fixture and fan filter unit by incorporating hospital-grade LED lighting inside each individual Krown-L module.

Reduced Ceiling Congestion

- Ideal for high cleanliness cleanrooms that require a significant portion of the ceiling to consist of fan filter units, integrated LED lighting conserves valuable ceiling space by eliminating the need for traditional light fixtures.

Optimized Equipment Layout

- Integrated LED lighting allows both airflow and the light source to be located directly above the work station to optimize visibility and ensure a contaminant free work area.

Improved Visibility

- The large light-emitting surface of each Krown-L module provides even lighting with a low luminous intensity to reduce glare on monitors and other reflective surfaces.
- Various lighting color temperatures and flexible dimming control can accommodate the unique requirements of modern laboratories, microelectronics manufacturing facilities, and other critical spaces.

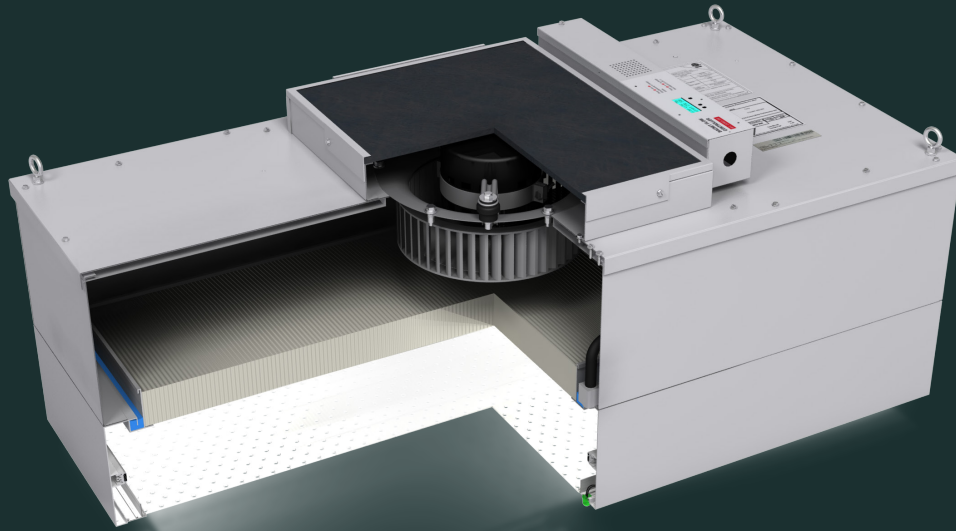

High Efficiency 100+
lm/W LED



L80 > 60,000 hours



Dimmable



IP67 Sealed LED



90+ CRI

The Krown - L is available with many of our standard Krown Fan Filter Series options, however it is not available with the following: Bench top replaceable filter, PSC motor, exhaust/reverse flow, stainless steel construction, room-side accessible controls, and seismic pre-approval.

Simple Installation & Maintenance

- Easy installation is realized as the LED lights and driver are factory installed and wired. Only two electrical connections are required, one at the LED driver and one at the control box.
- Integrated LED lighting is a sealed, IP67 rated fixture that effectively seals out debris and liquids.
- High quality LED lights have a long lifespan, rated at 80% original brightness for 60,000 hours. If required, individual LED strips are tool-free replaceable with quick-connect wiring.

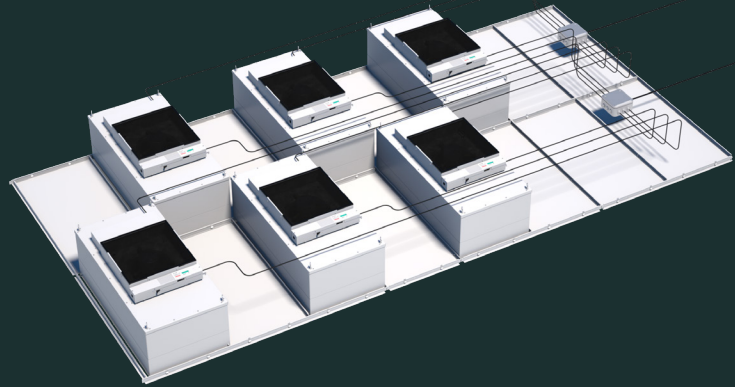

Electrical connection



Krown Fan Filter Units with integrated lighting installed

Code Compliance & Listings

NFPA 90A-2018 Installation of Air Conditioning and Ventilating Systems

ASHRAE 170-2017 Ventilation of Health-care Facilities

UL1598 Air-Handling Luminaries

UL 2043 Fire Test for Heat and Visible Smoke Release for Discrete Products and Their Accessories Installed in Air-Handling Spaces

UL2108 Low Voltage Lighting System

UL8750 Light Emitting Diode (LED) Equipment for Use in Lighting Products

UL1310 Class 2 Power Units

UL94 Flammability of Plastic Materials for Parts in Devices and Appliances

IP67 rated Ingress Protection Against Dust and Liquids

The Krown-L is available with many of our standard Krown Fan Filter Unit options, however it is not available with the following: bench top replaceable filter, PSC motor, exhaust/reverse flow, stainless steel construction, room-side accessible controls, and seismic pre-approval.

Room-side Filter and Motor Status Indication

An optional face-mounted color LED alerts the user when the filter is loaded and due for replacement, or if the motor is not operating properly. A green LED indicates normal operation, a yellow LED indicates a loaded filter and a red LED indicates an issue with the motor.



Speed Controllers

Speed controllers are a necessary component of Krown Fan Filter Units, providing precise control over the speed of the motor and the resultant airflow. Multiple speed controller options allow the user to select the best fit for each project.

PSC Speed Controller (PSCSC)

- Provides variable speed control of permanent split capacitor (PSC) motors.
- Airflow adjustments are made with the on-board dial that is fully adjustable from minimum to maximum speed, providing increased functionality over a three-speed switch.



Standard ECM Speed Controller (ECMSC)

- This low voltage speed controller offers either full manual control using the on-board dial or building automation system (BAS) control of a high-efficiency EC motor.
- Easily change from manual to BAS control by applying the BAS 0-10 VDC signal to the speed controller.



Wall Mounted ECM Speed Controller (WMSC)

- With simple daisy chain wiring, the Wall Mounted Speed Controller (ordered separately) controls Krown Fan Filter Units with ECMSC or BFC controllers.
- Using an analog 0-10 VDC signal, the WMSC is designed to control up to 30 units.



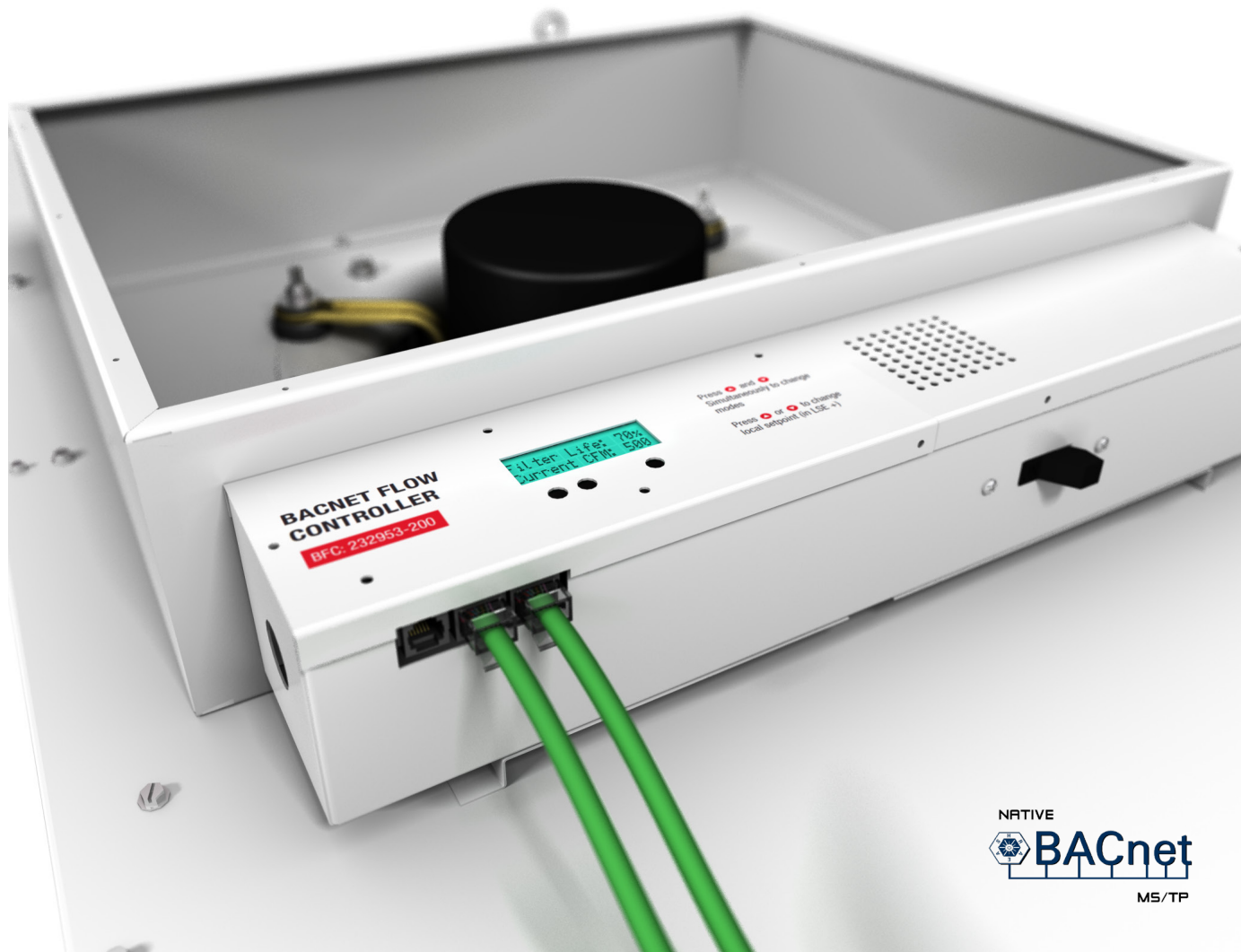

BACnet Flow Controller

The BACnet Flow Controller (BFC) offers seamless integration with BACnet building networks for unmatched control and visibility of Krown Fan Filter Units performance. Used in conjunction with EC motor technology, these native BACnet controllers facilitate adjustment and/or monitoring of parameters including CFM output and filter status.

Key Features

- Native BACnet MS/TP
- Backlit LCD display
- Several network points for control, monitoring or trending:
 - CFM output
 - Motor RPM and status
 - Motor hours
 - Filter status and pressure drop
 - Filter hours

Webserver Integration

Accessing your system via the internet allows worldwide access to the building for fast and easy monitoring and troubleshooting. The Webserver allows the user to view all status variables such as filter status, CFM, etc. for every Krown Fan Filter Unit on the network, as well as change any setpoints directly from a PC.

The Webserver comes with a pre-loaded graphic showing the status of each fan filter unit. Custom graphics and interfaces are available to show room layouts or airflow readouts for all units on one screen.

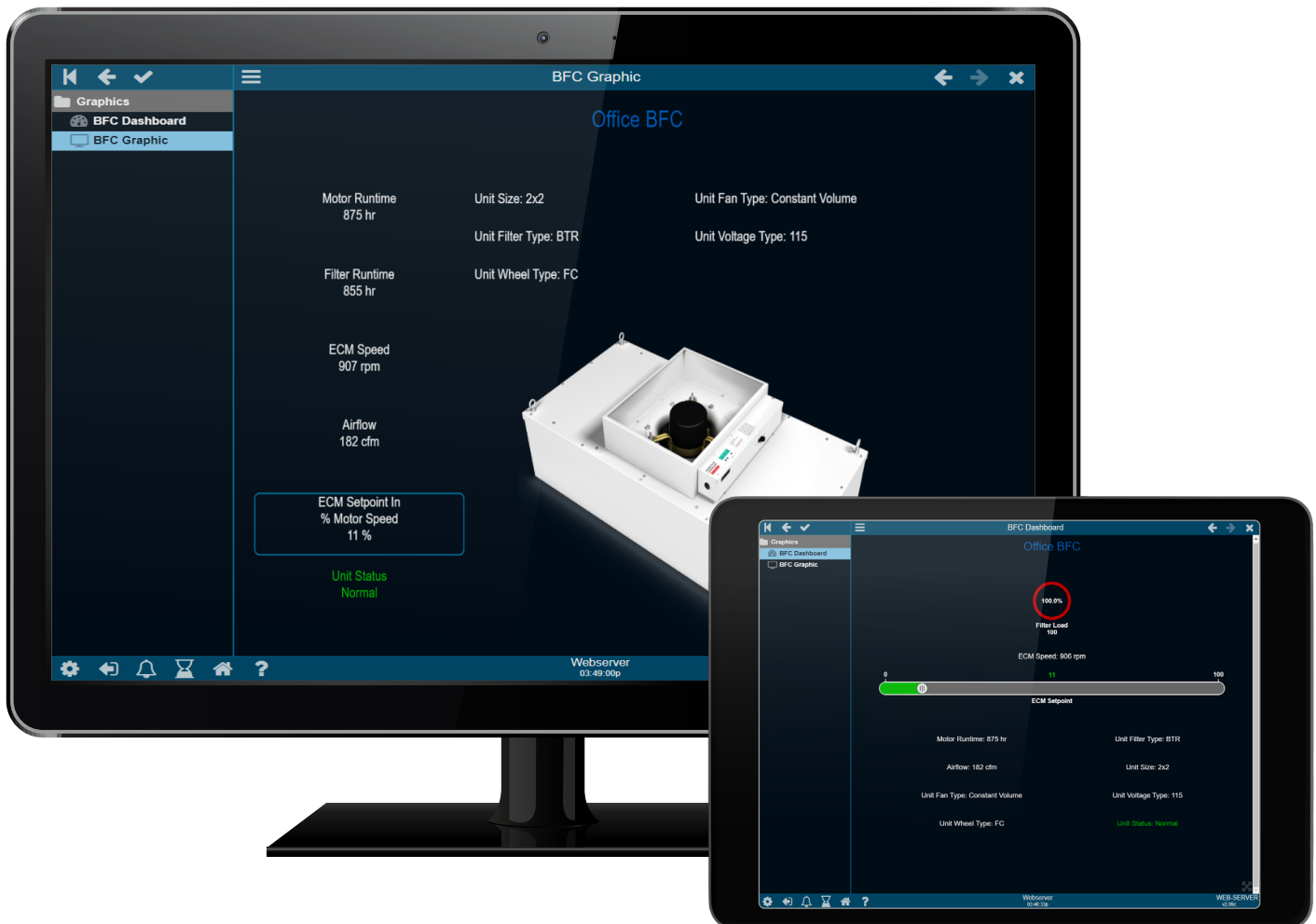
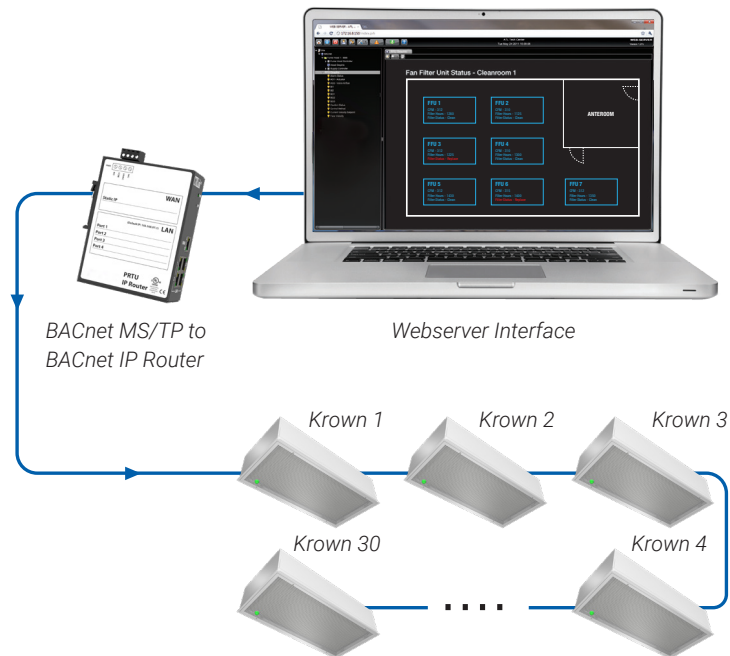

Room-side Accessible Controls

- The room-side accessible controls option features a rotating control box that allows access to the controls from both the top of the unit and from the room-side.
- To access the control box from the room-side remove the diffuser face, HEPA filter, and gasketed controls cover located inside the plenum.
- A disconnect switch is located on the face of the control box, and is easily accessible regardless of control box orientation.
- Optional room-side accessible controls are available with all speed controllers including the PSCSC, ECMSC, and BFC.

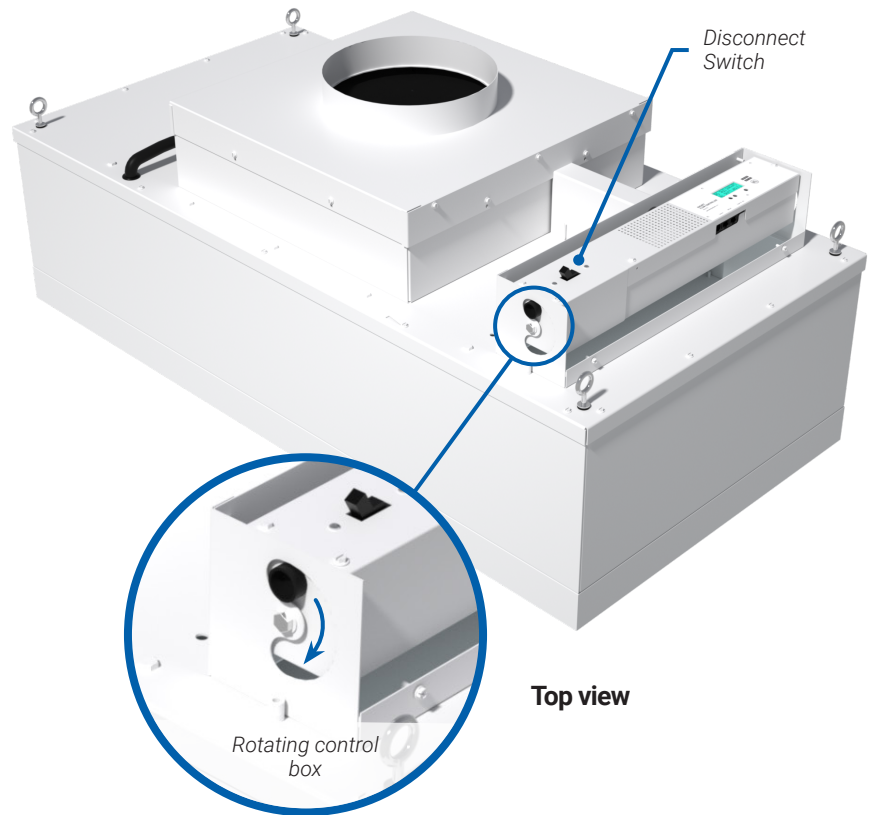

Dimensional Data

Krown Fan Filter Units/Krown-L

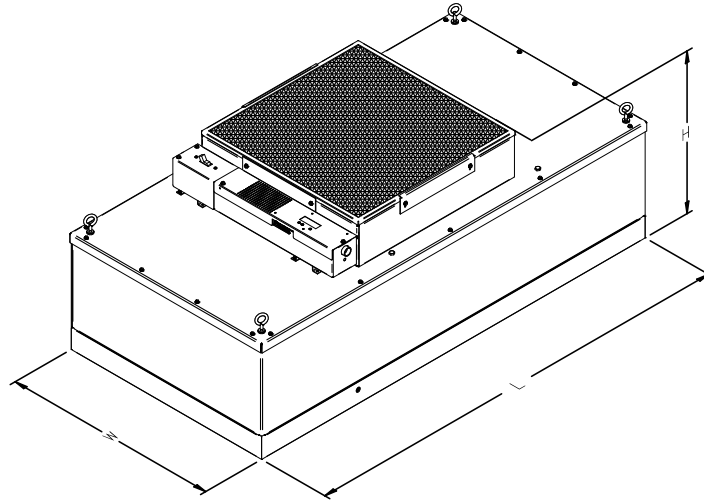

Unit Size	L (in.)	W (in.)	H (in.)					
			Standard			Integrated Lighting Krown-L		
			Ducted no Pre-Filter	Non-Ducted w/ Pre-Filter	Ducted w/ Pre-Filter	Ducted no Pre-Filter	Non-Ducted w/ Pre-Filter	Ducted w/ Pre-Filter
24 in. x 24 in.	23.625	23.625	17.350	18.300	18.800	21.500	22.450	22.950
24 in. x 36 in.	35.625	23.625	17.350	18.300	18.800	21.500	22.450	22.950
24 in. x 48 in.	47.625	23.625	17.350	18.300	18.800	21.500	22.450	22.950

Reverse Flow Krown Fan Filter Units with RSR Filter

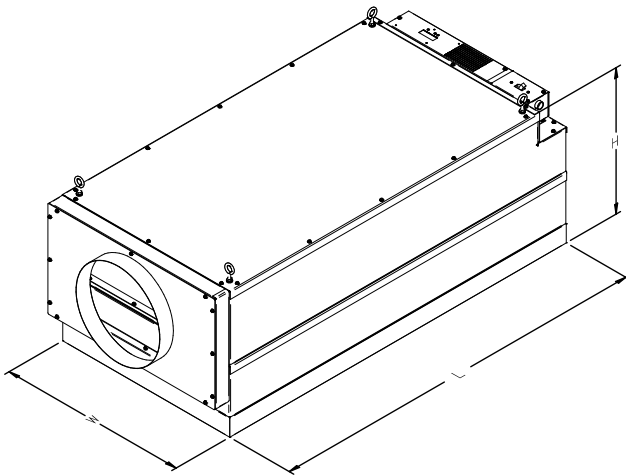

Unit Size	L (in.)	W (in.)	H (in.)
24 in. x 24 in.	23.625	23.625	20.500
24 in. x 48 in.	47.625	23.625	18.000

Supply Krown Fan Filter Units with BTR Filter

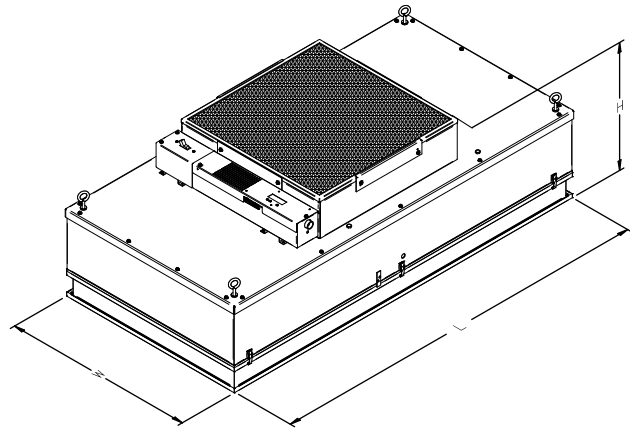

Unit Size	L (in.)	W (in.)	Ducted no PF	Non-Ducted w/ Pre-Filter	Ducted w/ Pre-Filter
24 in. x 24 in.	23.625	23.625	15.425	16.375	16.875
24 in. x 36 in.	35.625	23.625	15.425	16.375	16.875
24 in. x 48 in.	47.625	23.625	15.425	16.375	16.875

Performance Data

Supply

Unit Size	Filter	Motor - Fan	Active Filter Area (sq. ft.)	Max CFM	Watts at Max CFM	CFM at 90 FPM	Watts at 90 FPM	Sound (dBA) at 90 FPM	Weight (lbs.)
24 in. x 48 in.	BTR	ECM - BC	6.9	960	220	625	80	56	68
		ECM - FC	6.9	830	210	625	110	53	66
		PSC - BC	6.9	770	210	625	150	55	68
		PSC - FC	6.9	770	350	625	280	53	66
	RSR	ECM - BC	5.3	750	130	480	55	51	76
		ECM - FC	5.3	750	220	480	80	50	74
		PSC - BC	5.3	750	210	480	150	49	76
		PSC - FC	5.3	750	350	480	235	49	74
24 in. x 36 in.	BTR	ECM - BC	5.1	690	150	460	60	54	56
		ECM - FC	5.1	690	190	460	75	49	54
		PSC - BC	5.1	690	210	460	150	54	56
		PSC - FC	5.1	690	340	460	230	51	54
	RSR	ECM - BC	3.8	540	120	345	55	49	64
		ECM - FC	3.8	540	190	345	70	50	62
		PSC - BC	3.8	540	210	345	145	48	64
		PSC - FC	3.8	540	300	345	180	50	62
24 in. x 24 in.	BTR	ECM - FC	3.3	440	150	300	65	48	45
		PSC - FC	3.3	440	240	300	155	48	45
	RSR	ECM - FC	2.3	300	140	210	60	46	53
		PSC - FC	2.3	300	200	210	120	46	53

Integrated Lighting

Unit Size	Filter	Motor - Fan	Active Filter Area (sq. ft.)	Max cfm	Watts at Max cfm	cfm at 90 fpm	Watts at 90 fpm	Sound (dBA) at 90 fpm	Weight (lbs.)
24 in. x 48 in.	RSR	ECM - BC	5.3	750	165	480	65	54	106
		ECM - FC	5.3	750	230	480	80	50	104
ECM - BC		3.8	540	130	345	55	53	96	
ECM - FC		3.8	540	170	345	65	50	94	
24 in. x 24 in.		ECM - FC	2.3	300	140	210	70	46	74

Performance Notes:

- Units are tested in accordance with IEST RP-CC002.2, Recommended Practice for Unidirectional Flow Clean-Air Devices.
- Sound levels were measured with unit installed in a T-Bar ceiling, with gasket, in a standard room. Sound levels in dBA were measured at a distance of 30 inches from the filter face, with the unit set to produce 90 fpm average face velocity. (Note that data is for a clean filter only. If fan speed is increased to compensate for filter loading the noise level will increase.)
- For electrical circuit sizing, consult the "max amps" shown on the submittal for each product configuration and voltage.
- All data is based on a unit with a clean HEPA filter.
- 90 fpm values are based on active filter area.
- Heat Gain: BTUH = Watts x 3.413

Reverse Flow

Unit Size	Filter	Motor - Fan	Active Filter Area (sq. ft.)	Max CFM	Watts at Max CFM	CFM at 90 FPM	Watts at 90 FPM	Sound (dBA) at 90 FPM	Weight (lbs.)
24 in. x 48 in.	RSR	ECM - FC	5.3	750	140	480	60	52	74
		PSC - FC	5.3	750	210	480	120	50	74
ECM - FC		2.3	300	225	210	85	53	58	
PSC - FC		2.3	300	434	210	308	59	58	

Performance Notes:

- Units are tested in accordance with IEST RP-CC002.2, Recommended Practice for Unidirectional Flow Clean-Air Devices.
- Sound levels were measured with unit installed in a T-Bar ceiling, with gasket, in a standard room. Sound levels in dBA were measured at a distance of 30 inches from the filter face, with the unit set to produce 90 fpm average face velocity. (Note that data is for a clean filter only. If fan speed is increased to compensate for filter loading the noise level will increase.)
- For electrical circuit sizing, consult the "max amps" shown on the submittal for each product configuration and voltage.
- All data is based on a unit with a clean HEPA filter.
- 90 fpm values are based on active filter area.
- Heat Gain: BTUh = Watts x 3.413



Product Improvement is a continuing endeavour at Keystone Clean Air Solutions. Therefore, specifications are subject to change without notice. Consult Keystone directly for current specifications or more detailed information. Not all products may be available in all geographic areas. All goods described in this document are warranted as described in the Limited Warranty shown at **KeystoneCleanAir.com**. The complete Keystone product offering can be viewed online at **KeystoneCleanAir.com**.

® Keystone Clean Air Solutions is a registered trademark of Keystone Clean Air Solutions. © 2021. Printed in Canada.