

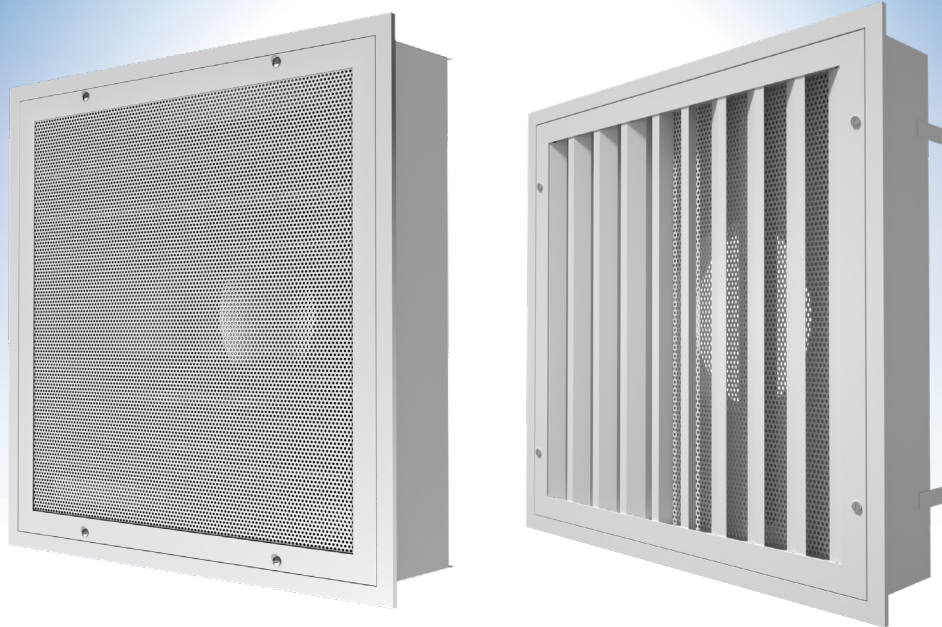

Arc

Radial Flow Diffuser with HEPA Filter



CATALOG

v001 – Issue Date: 03/20/2026

©2026 Keystone® Clean Air Solutions. All rights reserved.

Arc Radial Flow Diffuser with HEPA Filter

The Arc Radial Flow Diffuser with HEPA Filter is designed to deliver large volumes of filtered air with short throws to minimize velocity in the occupied zone, minimizing drafts and entrainment of room air. Ideal for use in laboratories, the Arc diffuser is able to provide large volumes of make-up air without adversely impacting containment at fume hoods.

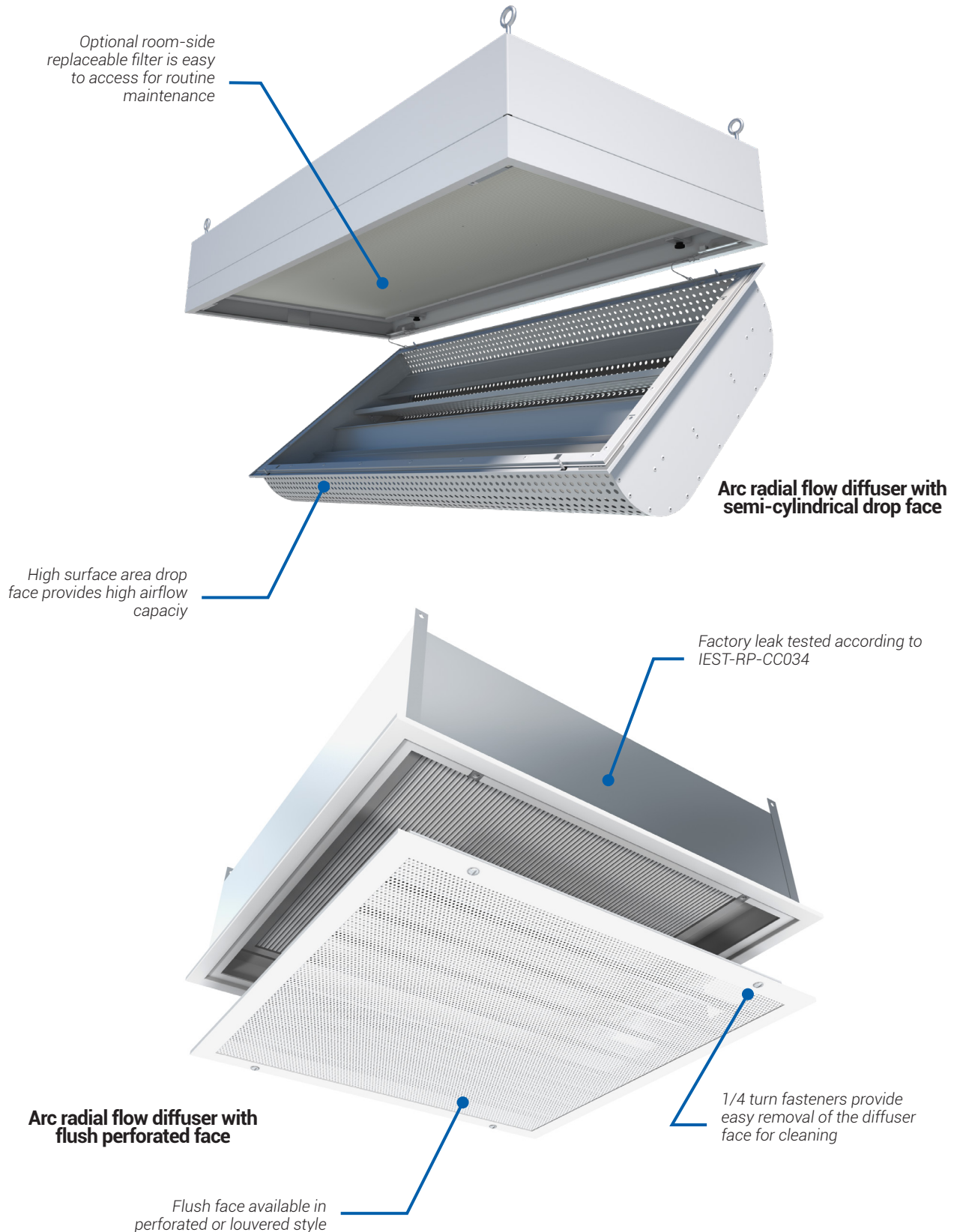

Superior Performance

- Optional semi-cylindrical drop face construction provides exceptional performance through the increased surface area of the face, producing low initial face velocity and minimizing entrainment of room air.
- The flush face design prevents interference with ceiling equipment such as sprinklers, while maintaining a radial airflow pattern.

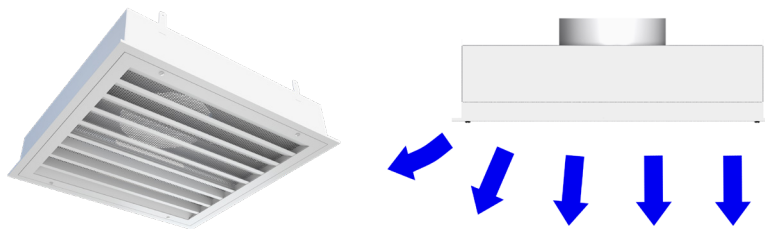

Flush louvered face with 1-way radial airflow (end view)

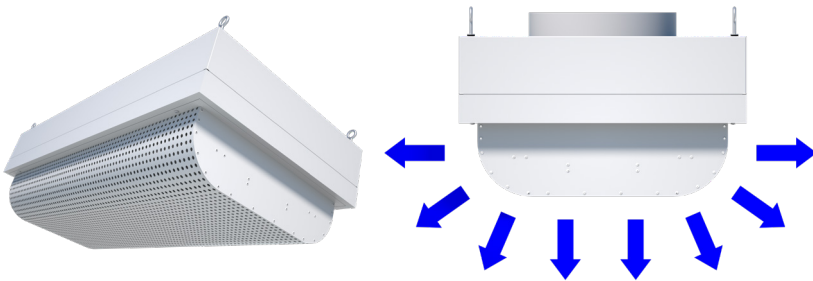

Semi-cylindrical drop face with 2-way radial airflow

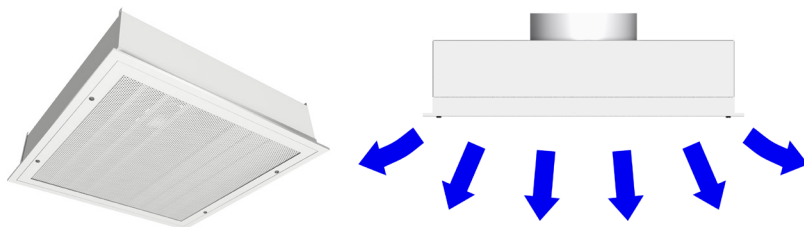

Flush perforated face with 2-way radial airflow (end view)

Cleaning and Maintenance

- Powder coat paint finish is formulated for routine exposure to hospital grade cleaning solutions and disinfectants.
- Stainless steel 1/4 turn fasteners and retainer cables provide straightforward and convenient access to the filter and knife-edge frame.
- Filters are easily removable for full access to the diffuser plenum for cleaning.

TYPICAL APPLICATIONS

The Arc Radial Flow Diffuser is commonly used in laboratories and airborne infectious isolation rooms where short throw and high capacity, filtered airflow are required. These diffusers are able to provide a high level of dilution while maintaining occupant comfort with a minimal number of diffusers.

CONSTRUCTION

- Material
 - Aluminum
 - Stainless steel
 - Hybrid
- Style
 - Semi-cylindrical drop face
 - Flush louvered face
 - Flush perforated face
- Options
 - LED filter status indicator
 - Room-side adjustable damper
 - Aerosol test system (INJ)
 - Equalization basket
 - Casing insulation

Room-Side Replaceable Filter

- Convenient access from the room-side for periodic filter replacement.
- Gel seal filter frame and diffuser "knife edge" flange create a reliable seal to prevent filter bypass.
- Compatible with factory supplied HEPA filter for removal of 99.99% of contaminants or filter replacement baffle.

LED Filter Status Indicator

- An optional LED filter status light, visible from the room-side, changes from green to yellow when the filter is loaded and due for replacement.
- The LED light is factory calibrated to trigger when the filter pressure drop has increased by 50% above that of an unloaded filter and can be adjusted in the field to suit facility preferences.

Room-Side Adjustable Inlet Damper

- An optional remote cable operator allows adjustment of the damper with the filter in place using a standard screwdriver.
- Locating the damper operator outside of the filter maximizes filter area, leading to a larger airflow capacity and less pressure drop.

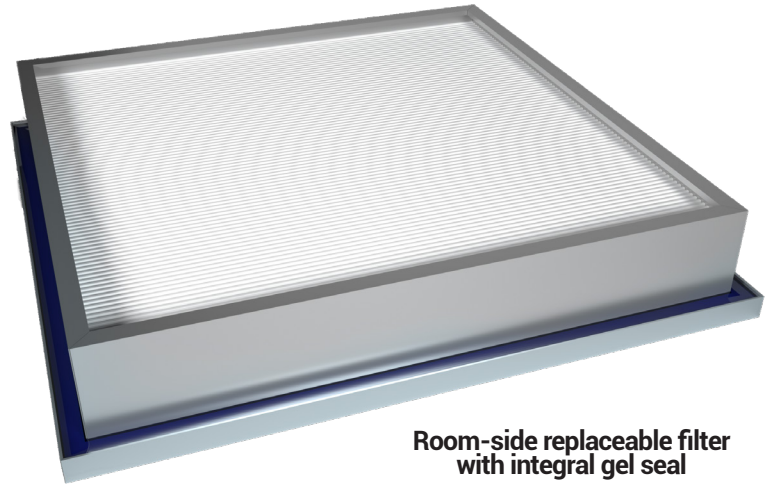

Room-side replaceable filter with integral gel seal

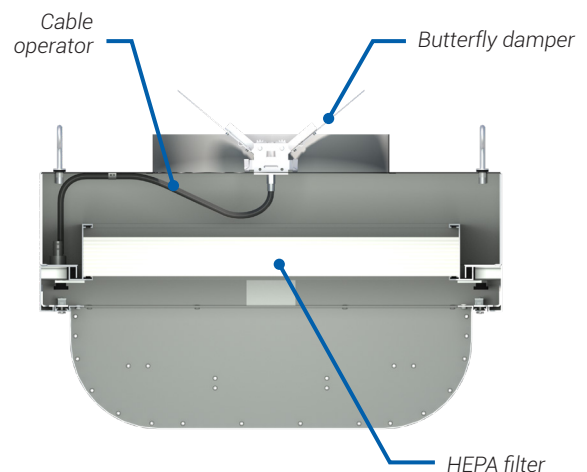
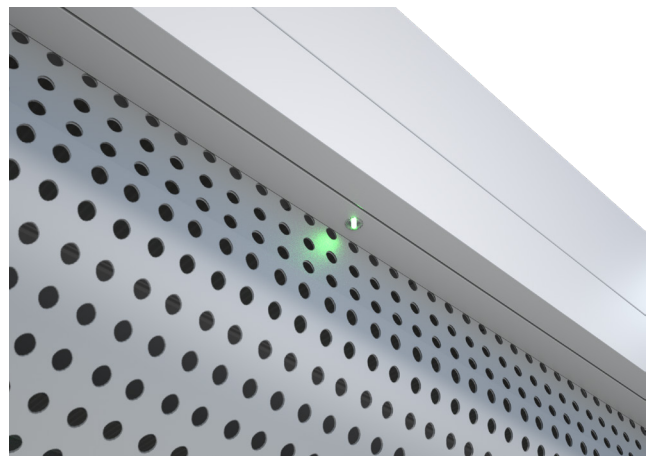

Room-side adjustable damper cross sectional view

Equalization Basket

- The optional equalization basket, located beneath the inlet, equalizes airflow and ensures even loading across the filter.

Factory Leak Testing and Certification

- Every Arc Radial Flow Diffuser is factory tested and certified leak-free in accordance with IEST-RP-CC034.

Aerosol Sampling and Static Pressure Port

- Used for room-side field measurement of static pressure and challenge aerosol concentrations upstream of the filter during the commissioning process.



Aerosol Test System

- Unique and convenient option when upstream aerosol injection during field commissioning is impractical.
- The aerosol injection port (3/8 in. female NPT) and aerosol sample and static pressure port facilitate the complete room-side aerosol challenge of the diffuser.
- Stainless steel aerosol dispersion ring for equalized aerosol challenge across the entire active filter area.

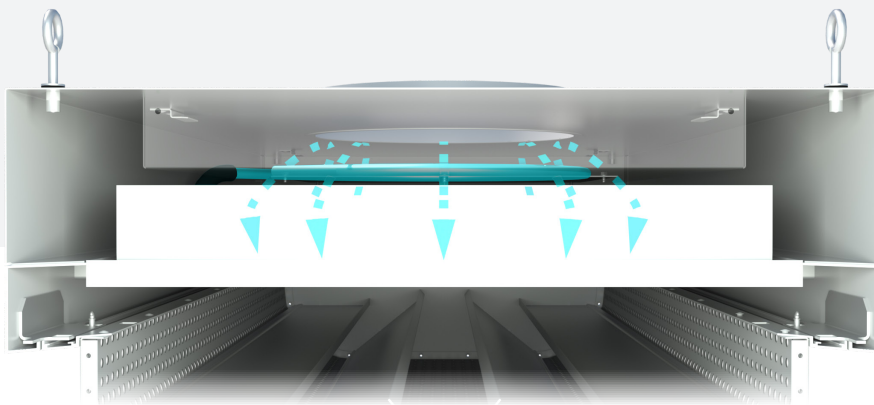

Exterior Insulation

- Ensures quality application and minimizes field labor with factory installed insulation.
- Eliminates condensation risk associated with unconditioned plenum air exposure to cold diffuser surfaces.
- Reduces thermal gain for improved energy savings.
- Meets ASTM E84 and UL723 requirements.

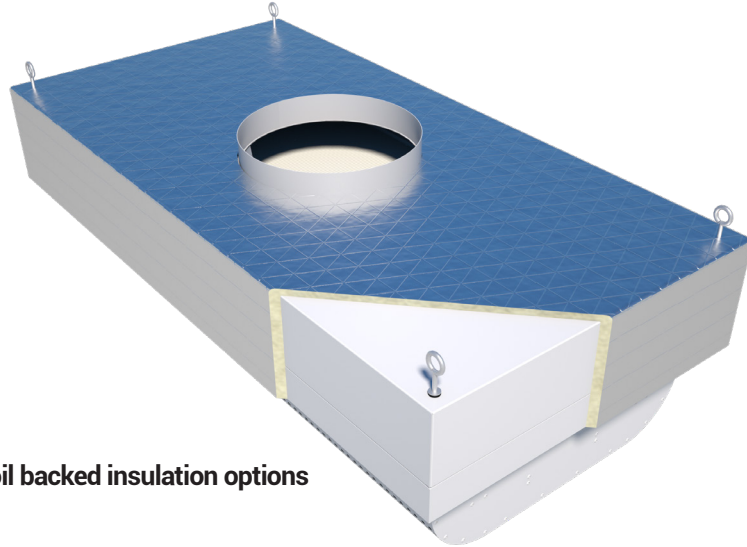

0.5" and 1.5" foil backed insulation options



Dimensional Data

Semi-Cylindrical Drop Face

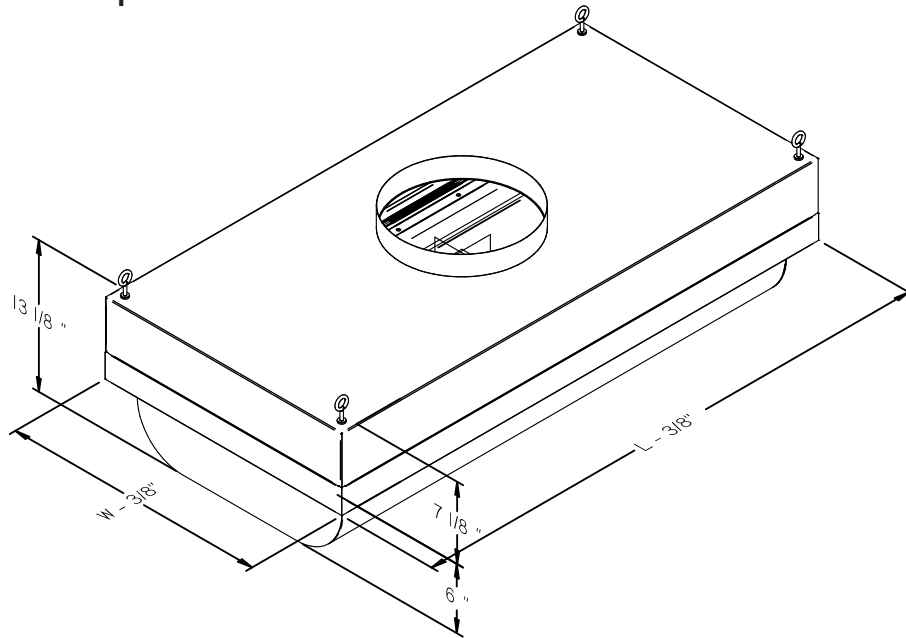

Nominal Sizes		
Airflow Pattern	W x L	Inlet Sizes
1-way	12 in. x 48 in.	6, 8
2-way	24 in. x 24 in.	6, 8, 10, 12
2-way	24 in. x 48 in.	6, 8, 10, 12

Flush Face

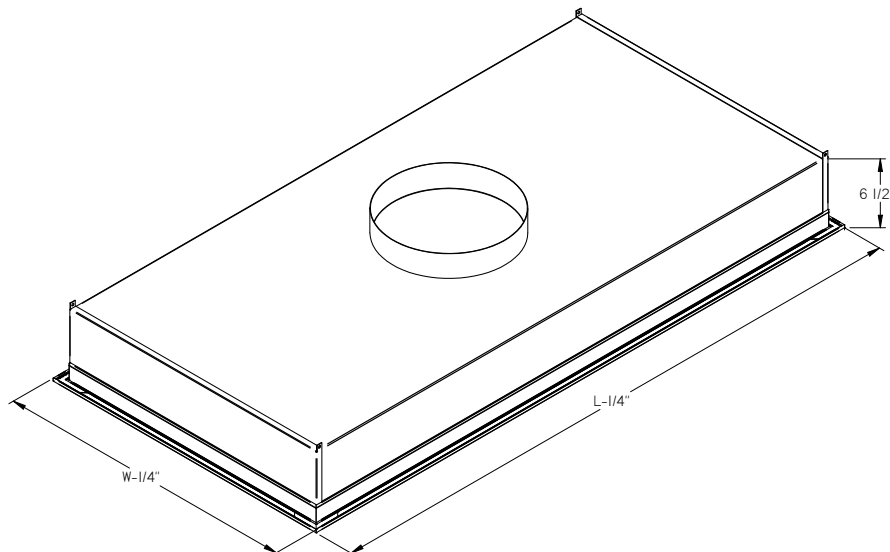

Nominal Sizes	
W x L	Inlet Sizes
24 in. x 24 in.	10
24 in. x 48 in.	12

Performance Data

Semi-Cylindrical Drop Face

Unit Size (in.)	Inlet Size (in.)	Air Flow (CFM)	Filter	Static Pressure (in. w.g.)	Sound (NC)	Vertical Throw (ft.) 100-50 FPM	Horizontal Throw (ft.) 100-50 FPM
24 x 24 (600 x 600mm)	8	150	HEPA	0.3	-	2.0-7.5	0.5-2.0
		200		0.4	-	2.0-7.5	0.5-3.0
		250		0.51	-	3.5-7.5	1.5-4.0
		150	ULPA	0.38	-	0.0-7.5	0.0-2.0
		200		0.52	-	3.0-7.5	0.0-3.0
		250		0.64	-	3.0-7.5	1.0-4.0
	10	HEPA	150	0.29	-	0.0-7.5	0.0-1.5
			200	0.39	-	2.5-7.5	0.5-3.0
			250	0.49	-	3.0-7.5	1.5-3.0
		ULPA	150	0.38	-	0.0-7.5	0.0-2.0
			200	0.51	-	2.0-7.5	0.0-3.0
			250	0.64	-	2.5-7.5	2.0-4.0
	12	HEPA	150	0.28	-	0.0-7.5	0.0-1.5
			200	0.38	-	3.0-8.0	0.5-3.0
			250	0.48	-	3.0-8.0	2.0-3.0
ULPA		150	0.28	-	2.0-7.5	0.0-1.5	
		200	0.5	-	3.0-8.0	1.0-3.0	
		250	0.63	-	4.0-8.0	1.0-3.5	
24 x 48 (600 x 1200mm)	10	HEPA	300	0.24	-	5.0-7.0	0.5-2.0
			400	0.33	19	3.0-7.0	2.0-3.5
			500	0.43	26	0.5-7.0	1.0-6.0
		600	0.54	32	2.0-7.0	1.0-6.5	
		ULPA	300	0.23	-	6.0-8.0	1.0-2.5
			400	0.32	18	4.0-8.0	2.0-3.5
	500		0.41	25	1.0-7.0	1.0-5.5	
	12	HEPA	600	0.52	31	3.0-8.0	3.0-7.0
			300	0.23	-	5.0-8.0	0.0-1.0
			400	0.32	-	5.0-8.0	1.5-2.5
		ULPA	500	0.41	16	1.0-8.0	1.0-3.0
			600	0.52	21	1.0-7.0	1.0-5.0
			300	0.29	-	5.5-8.0	0.5-1.5
	12	ULPA	400	0.4	-	4.0-8.0	0.0-2.0
			500	0.51	15	0.0-8.0	0.5-4.0
			600	0.63	21	0.0-7.0	2.0-5.5

Performance Notes:

1. sp = Static Pressure, in. w.g., required at inlet for the listed cfm.
2. cfm = Air flow in cubic feet per minute, cfm.
3. NC = Noise Criteria. NC values are based on room absorption of 10dB, re 10^{-12} watts.
4. Blanks "-" indicate an NC level below 10.
5. Throw values are given in feet to terminal velocities of 100 fpm (minimum) and 50 fpm (maximum).
6. Throw values are based on vertical pattern at 10 °F cooling.
7. sp and NC at full open damper position.
8. Tested in accordance with ASHRAE Standard 70-2006 "Method of Testing for Rating the Performance of Air Outlets and Inlets."

Flush Face

Unit Size (in.)	Inlet Size (in.)	Air Flow (cfm)	Static Pressure (in. w.g.)	Total Pressure (in. w.g.)	Sound (NC)	Throw (ft.) 100 - 75 - 50 fpm					
						Vertical			Horizontal		
						5 °F	10 °F	15 °F	5 °F	10 °F	15 °F
24 x 24	10	150	0.220	0.225	-	1-2-3	1-3-4	2-4-5	1-1-2	1-2-2	2-2-2
		200	0.320	0.328	-	1-3-5	1-3-5	2-3-5	1-2-3	1-2-3	2-2-2
		300	0.550	0.569	-	2-3-5	3-4-5	4-5-6	3-4-5	3-4-5	3-3-4
24 x 48	12	500	0.485	0.510	22	3-4-6	5-6-7	2-4-8	2-2-2	1-1-2	1-1-2
		600	0.607	0.643	29	3-4-7	3-5-7	4-6-8	2-2-3	2-2-3	2-2-2
		700	0.729	0.778	32	5-6-8	4-6-8	5-6-8	3-3-4	2-3-3	2-2-3

Performance Notes:

1. Units are tested in accordance with ASHRAE Standard 70-2006.
2. Air flow is in cubic feet per minute, cfm.
3. All pressures are in in. of water.
4. The NC values, sound pressure level, are based on a room absorption of 10 dB re 10^{-12} watts and one diffuser.
5. Blanks "-" indicate an NC value below 20.
6. Performance is based on diffuser with HEPA filter.



Product Improvement is a continuing endeavour at Keystone Clean Air Solutions. Therefore, specifications are subject to change without notice. Consult Keystone directly for current specifications or more detailed information. Not all products may be available in all geographic areas. All goods described in this document are warranted as described in the Limited Warranty shown at **KeystoneCleanAir.com**. The complete Keystone product offering can be viewed online at **KeystoneCleanAir.com**.

® Keystone Clean Air Solutions is a registered trademark of Keystone Clean Air Solutions. © 2026. Printed in Canada.